

DOLECO

USA

Supplement June 2025



- **Cargo Restraint Solutions**
- **Lifting Solutions**
- **Innovation**



Everlast 500 Web Winches

All winches shown below are right hand models unless otherwise specified.

- Stamped working load limit and Doleco name certify quality



Portable Stake Pocket

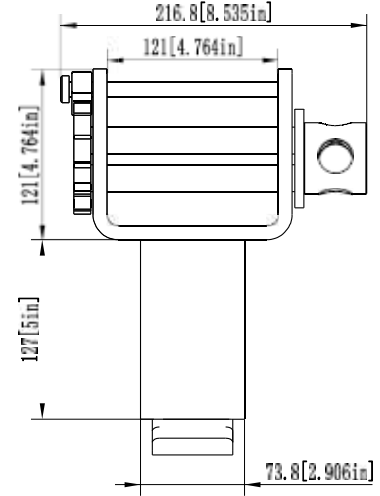
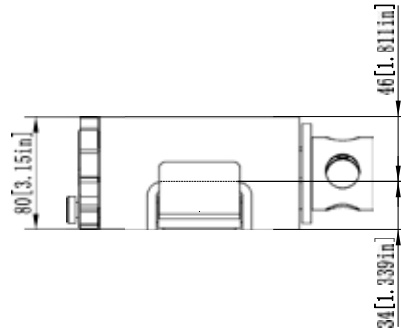

Weight:	11.5 lbs./5.2 kgs.
WLL:	5,500 lbs./2,500 kgs.
Part No.:	2812 0056



Storage Double L Track Slider

Weight:	7.0 lbs./3.2 kgs.
WLL:	5,500 lbs./2,500 kgs.
Part No.:	2812 0031

For Winch dimensions, see full line catalog item number C-0422.



Standard Double L Track Slider

Weight:	6.5 lbs./2.9 kgs.
WLL:	5,500 lbs./2,500 kgs.
Part No.:	2812 0033

For Winch dimensions, see full line catalog item number C-0422.



Low Profile Double L Track Slider

Weight:	7.0 lbs./3.2 kgs.
WLL:	5,500 lbs./2,500 kgs.
Part No.:	2812 0035

For Winch dimensions, see full line catalog item number C-0422.



3-Bar Standard Double L Slider

Weight:	11.55 lbs./5.24 kgs.
WLL:	5,500 lbs./2,500 kgs.
Part No.:	2812 0052

For Winch dimensions, see full line catalog item number C-0422.



Portable Angle Bolt-On

Weight:	8.25 lbs./3.74 kgs.
WLL:	5,500 lbs./2,500 kgs.
Part No.:	2812 0047

For Winch dimensions, see full line catalog item number C-0422.



3-Bar Double L Lo Pro

Weight:	9.1 lbs./4.13 kgs.
WLL:	5,500 lbs./2,500 kgs.
Part No.:	2812 0046



Double L Lo Pro Receiver

Weight:	4.9 lbs./2.22 kgs.
WLL:	5,500 lbs./2,500 kgs.
Part No.:	2842 0020



Double L Slider Track Hook

Weight:	5.65 lbs./2.56 kgs.
WLL:	5,500 lbs./2,500 kgs.
Part No.:	2842 0009



Transport Chain

Available in box, pail, drum or barrel. Labels color-coded by chain diameter;
1/4" Brown; 5/16" Orange; 3/8" Green; 1/2" Red.



New Grade 100 Alloy Chains

Part No.:	Size:	Weight:	WLL:
2358 5100	Grade 100 5/16" bulk chain	5,700 lbs./2,585 kgs.	500 feet per barrel 560 lbs. net. 152.4 meters per barrel 254 kgs. net.
2358 3100	Grade 100 3/8" bulk chain	8,800 lbs./3,992 kgs.	500 feet per barrel 760 lbs. net. 152.4 meters per barrel 232 kgs. net.
2358 2100	Grade 100 1/2" bulk chain	15,000 lbs./6,804 kgs.	300 feet per barrel 813 lbs. net 91.4 meters per barrel 368.8 kgs. net.
2358 4100	Grade 100 3/4" bulk chain	35,300 lbs./16,012 kgs.	100 feet per barrel 630 lbs. net. 30.5 meters per barrel 285.8 kgs. net.



D-Rings

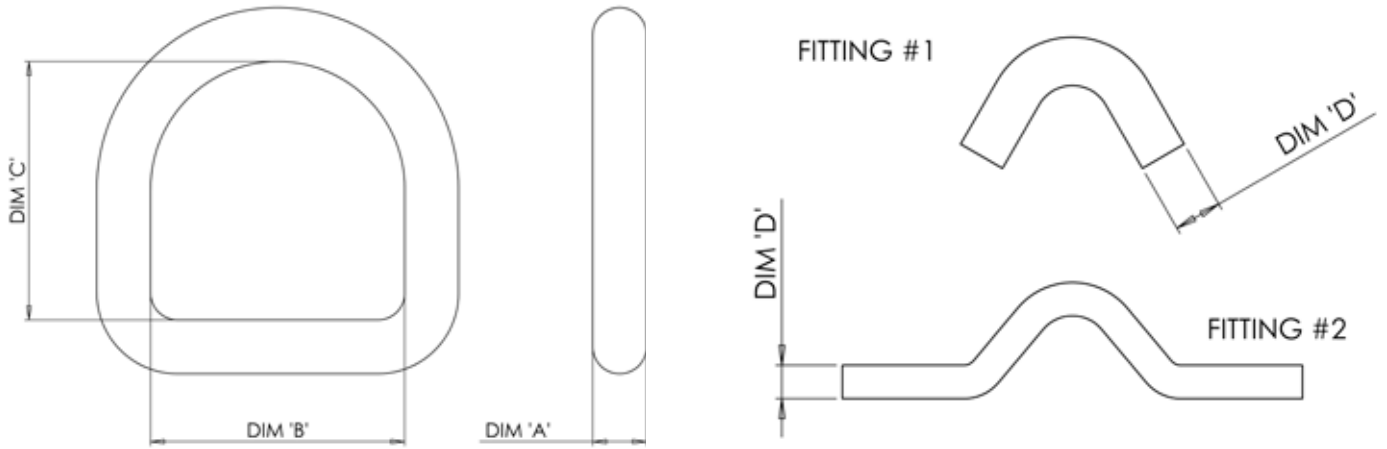

D-Rings

Part No.:	Dimensions				Fitting No.:
	A	B	C	D	
2840 0001	1/2"/12.7 mm	2.36"/60 mm	2.36"/60 mm	0.22"/5.5 mm	#2
2840 0002	1/2"/12.7 mm	2.36"/60 mm	2.40"/61 mm	0.31"/8.0 mm	#1
2840 0003	5/8"/15.88 mm	2.95"/75mm	2.95"/75 mm	0.37"/9.5 mm	#1
2840 0004	3/4"/19.05 mm	2.95"/75 mm	2.95"/75 mm	0.37"/9.5 mm	#1
2840 0005	1"/25.4 mm	2.95"/75 mm	2.95"/75 mm	0.39"/10.0 mm	#1



FastBinder Folding Handle Load Binder

Part No.:	Size:	Weight:	WLL:
2350 5614	5/16"-3/8" G70-G80	10.91 lbs./4.95 kgs.	7,100 lbs./3,221 kgs.
2350 3814	3/8"-1/2" G70-G80	13.36 lbs./4.70 kgs.	12,000 lbs./5,443 kgs.



DoQuick—Unique Patented Ratchet Load Tensioner

Simply quicker tensioning

Saving time and energy

With the quick release mechanism you never have to unscrew the thread by hand again, but can pull it out completely in less than a second.

Pre-tightening also works very easily, as you can simply "push" the threaded rod into the tensioner.

Space-saving

Due to the very short lever, the DoQuick can be used in a space-saving manner and can be stowed away when not in use.

Safely apply force

The swivel eye prevents unintentional twisting of the lashing chain—pretensioning forces can always be achieved.

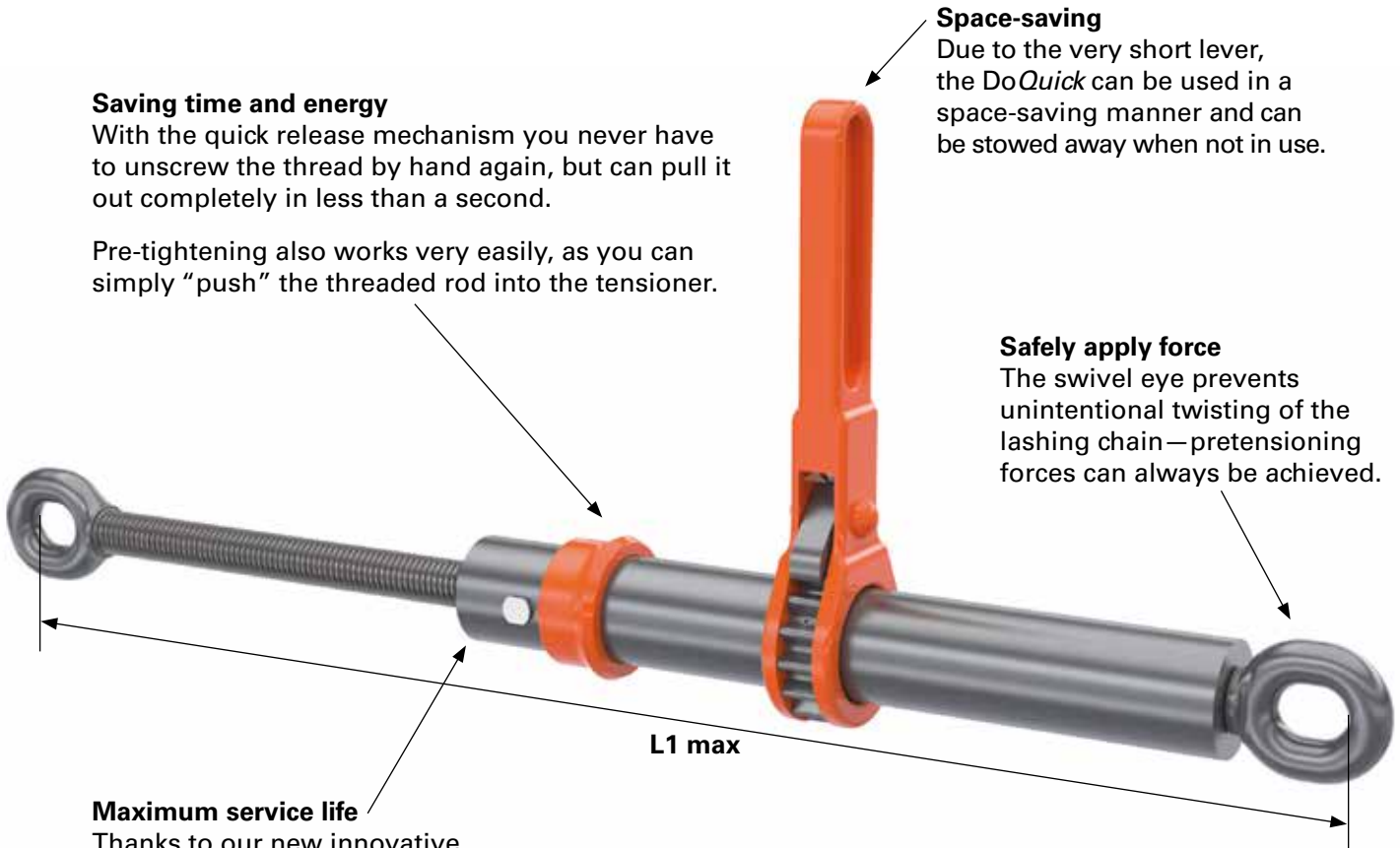

Maximum service life

Thanks to our new innovative unscrewing protection, especially for the DoQuick, threaded rods can never be overtightened again.

Double tensioning travel

Compared to a standard ratchet tensioner, the DoQuick, has twice the tensioning-distance: This makes hooking the chains much less strenuous, as you do not have to pre-tighten the chain as much in the beginning.

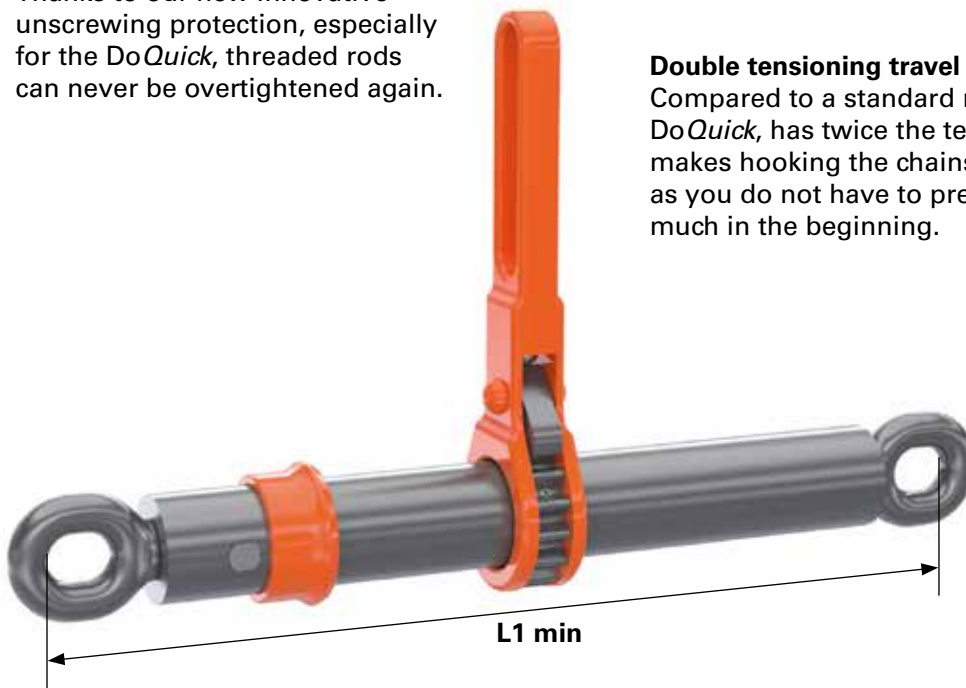



DoQuick Load Binder

Part No.:	Size:	Weight:	WLL:
0385 2101	25/8 chain	13.40 lbs./2,585 kgs.	22,000 lbs./9,9979 kgs.
0385 2102	25/8 chain	17.61 lbs./7.99 kgs.	22,000 lbs./9,9979 kgs.

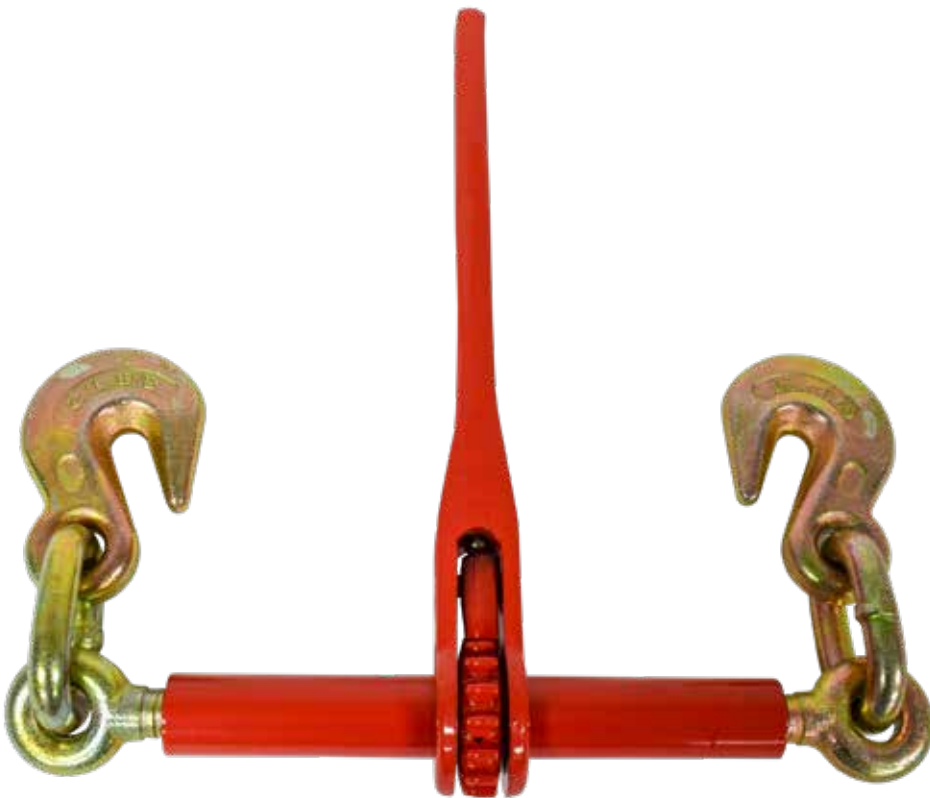

Higher WLL Ratchet Binder

Part No.:	Size:	Weight:	WLL:
2350 3832	3/8"-1/2" G100-G80 Single Handle	12.85 lbs.	12,000 lbs./5,443 kgs.



Double Clevis Link

Part No.:	Description:	Weight:	WLL:
2360 0041	G70-Zinc Plated, 1/4"-5/16"	0.3 lbs./0.14 kgs.	4,700 lbs./2,132 kgs.
2360 0042	G70-Zinc Plated, 3/8"	0.4 lbs./0.18 kgs.	6,600 lbs./2,994 kgs.
2360 0044	G70-Zinc Plated, 7/16"-1/2"	1.0 lbs./0.45 kgs.	11,300 lbs./5,125 kgs.



Round Sling Hooks

Part No.:	Size:	Weight:	WLL:
2358 0007	1T	0.73 lbs./0.33 kgs.	2,000 lbs./908 kgs.
2358 0008	2T	1.27 lbs./0.58 kgs.	4,000 lbs./1,814 kgs.
2358 0009	3T	2.3 lbs./1.04 kgs.	6,000 lbs./2,722 kgs.
2358 0010	4T	4.615 lbs./2.09 kgs.	8,000 lbs./3,629 kgs.
2358 0011	5T	4.615 lbs./2.09 kgs.	10,000 lbs./4,536 kgs.
2358 0012	6T	4.615 lbs./2.09 kgs.	12,000 lbs./9,072 kgs.



Grade 100 Sling Hooks

Part No.:	Size:	Weight:	WLL:
2358 1056	5/16"	1.32 lbs./0.6 kgs.	5,500 lbs./2,500 kgs.
2358 1038	3/8"	2.87 lbs./1.3 kgs.	8,800 lbs./4,000 kgs.
2358 1012	1/2"	5.07 lbs./2.3 kgs.	14,700 lbs./6,668 kgs.
2358 1058	5/8"	7.94 lbs./3.6 kgs.	22,000 lbs./9,979 kgs.



Grade 100 Clevis Shortening Grab Hooks

Part No.:	Size:	Weight:	WLL:
2358 1156	5/16"	0.75 lbs./0.34 kgs.	5,500 lbs./2,500 kgs.
2358 1138	3/8"	1.81 lbs./0.82 kgs.	8,800 lbs./4,000 kgs.
2358 1112	1/2"	3.86 lbs./1.75 kgs.	14,700 lbs./6,668 kgs.
2358 1158	5/8"	6.35 lbs./2.88 kgs.	22,000 lbs./9,979 kgs.



Grade 100 Connecting Links

Part No.:	Size:	Weight:	WLL:
2358 1256	5/16"	0.40 lbs./0.18 kgs.	5,500 lbs./2,500 kgs.
2358 1238	3/8"	0.75 lbs./0.34 kgs.	8,800 lbs./4,000 kgs.
2358 1212	1/2"	1.50 lbs./0.68 kgs.	14,700 lbs./6,668 kgs.
2358 1258	5/8"	2.69 lbs./1.22 kgs.	22,000 lbs./9,979 kgs.

Utility Tiedowns

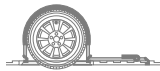

Door Limit Strap



Weight:	0.75 lbs./0.34 kgs.
WLL:	800 lbs./363 kgs.
Part No.:	3320 0041

32" from end of hook to end of hook.



3800 0034



3800 0035



3800 0036

Retractable Tiedowns

Part No.:	Description:	Weight:	WLL:
3800 0034	1" x 14' Padded Ratchet tiedown w/ S-Hooks - 2PK	1.958 lbs./0.89 kgs.	500 lbs./227 kgs.
3800 0035	1" x 14' Padded Ratchet tiedown w/ S-Hooks - 4PK	3.652 lbs./1.66 kgs.	500 lbs./227 kgs.
3800 0036	1.25" x 14' Padded Ratchet tiedown Assembly	1.87 lbs./0.85 kgs.	1000 lbs./455 kgs.



5845 0009



5845 0010



5845 0011



5845 0012

E-Track Brackets

Part No.:	Description:	Weight:	WLL:
5845 0009	Spare Tire Holder	0.638 lbs./0.29 kgs.	N/A.
5845 0010	4.25" Round J-Hook	0.902 lbs./0.41 kgs.	200 lbs./91 kgs.
5845 0011	2" Square J-Hook	0.418 lbs./0.19 kgs.	200 lbs./91 kgs.
5845 0012	Double L Hook	1.452 lbs./0.66 kgs.	200 lbs./91 kgs.

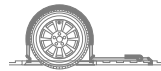

Driver Assist Strap

Part No.:	Description:	Size:
3359 0033	Driver Assist Strap 3-loop	44"
3359 0034	Driver Assist Strap single-loop	36"



6818 0215/6818 0225



6819 0220/6819 0320



6819 0430/6819 0630

Recovery and Tow Straps

Part No.:	Description:	Weight:	WLL:
6818 0215	Tow Strap, 15' x 2"	5,500 lbs./2,500 kgs.	2.25 lbs./1.02 kgs.
6818 0225	Tow Strap, 25' x 2"	5,500 lbs./2,500 kgs.	2.85 lbs./1.29 kgs.
6818 0220	Recovery Strap, 20' x 2"	7,000 lbs./3,175 kgs.	1.8 lbs./0.82 kgs.
6818 0320	Recovery Strap, 20' x 3"	11,000 lbs./4,990 kgs.	3.05 lbs./1.38 kgs.
6818 0430	Recovery Strap, 30' x 4"	10,000 lbs./5,536 kgs.	4.8 lbs./2.18 kgs.
6818 0630	Recovery Strap, 30' x 6"	30,000 lbs./13,608 kgs.	11.8 lbs./5.35 kgs.

Textile Chains



DoRa

Doleco's DoRa Ratcheting Load Binder is 20 Percent Shorter Than Others, Extends to Twice Their Length and Makes Chain Retensioning a Breeze

The patented spindle-in-a-spindle design of the DoRa Ratcheting Load Binder saves time, giving users unrivaled tensioning capabilities when securing cargo with steel chains, and is designed to work as a system with Doleco's DoNova PowerLash Textile Lashing Chain (shown right).

At just three quarters as long as a standard load binder, the DoRa fits into tighter spaces, but expands to enable users to reach twice as far as any other. The compact size and extra length of the DoRa save users time and trouble, because they don't have to detach and reattach chains when periodically retensioning cargo.

Since the majority of cargo securement applications involve steel chains, the DoRa comes standard with clevis hooks. However, the DoRa Ratcheting Load Binder is also designed to work as a system with Doleco's DoNova PowerLash Textile Lashing Chain, and for those applications can be ordered with a slip hook and keeper on both ends of its spindles.

Doleco's revolutionary textile chain is made of high-performance Dyneema fiber. Dyneema's ultra-high-molecular-weight polyethylene (UHMWPE) material is 15 times stronger than steel by weight, and made into chain, up to 85 percent lighter—so lightweight, in fact, that it floats on water.



0385 0101



0385 0149
0385 0159
0385 0169

DoRa load binders for use with DoNova® Powerlash Textile Chains

Part No.:	Description:	Chain Size:	Weight:	WLL:
0385 0101	DoRa 100 for DoNova	25/8	14.11 lbs./6.4 kgs.	22,480 lbs./10,197 kgs.
0385 0149	DoRa 200 for DoNova	30/10	14.11 lbs./6.4 kgs.	44,961 lbs./20,394 kgs.
0385 0159	DoRa 200 for DoNova	30/8	22.73 lbs./10.31 kgs.	35,969 lbs./16,315 kgs.
0385 0169	DoRa 200 for DoNova	25/10	22.73 lbs./10.31 kgs.	28,101 lbs./12,746 kgs.

Introducing
ProDeck™
By Doleco



**Smooth Operation,
Every Time!**

The only double-deck system with patented, non-stick foot assemblies that glide freely, even under load.

ProDeck™ by Doleco solves the most frustrating problem in double deck systems—stuck beams. Our revolutionary wear-resistant foot assemblies feature patented clip-on pads made of an advanced material that glide smoothly in the track or when track alignment is effected by trailer walls flexing. This simple but powerful innovation eliminates the costly equipment damage and downtime caused by stuck beams and desperate attempts to force them free, particularly with forklifts.

Combined with our modular beam designs and premium engineering, ProDeck™ delivers the reliability, durability and efficiency that modern fleets demand. Experience the future of double decking—where every beam moves precisely when and where you need it to.

ProDeck™: The Future of Double Decking

Elevate your logistics game with ProDeck™, the groundbreaking double decking system designed to redefine efficiency and maximize payload capacity in semi-trailers. Engineered for innovation, ProDeck™ offers a lightweight yet robust solution that enables seamless stacking of products, ensuring you can transport more without compromising on stability or safety.

At the heart of ProDeck™ lies pioneering technology, protected by multiple patents, including our revolutionary clip-on wide top and durable plastic wear pads on the foot assembly. These features provide unmatched ease of use and longevity, even under the toughest conditions. The foot assembly's wide, stable base creates a rock-solid foundation, ensuring reliable performance mile after mile.

Designed to help you make the most of every journey, ProDeck™ is your partner in maximizing payload capacity, reducing costs, and boosting operational efficiency. It's not just a decking system—it's a logistics revolution.



ProDeck™: Stack Smarter. Deliver More.

- Precision-machined tracks for smooth and secure operation.
- Available in a variety of track options, fully customizable to meet your exact requirements.

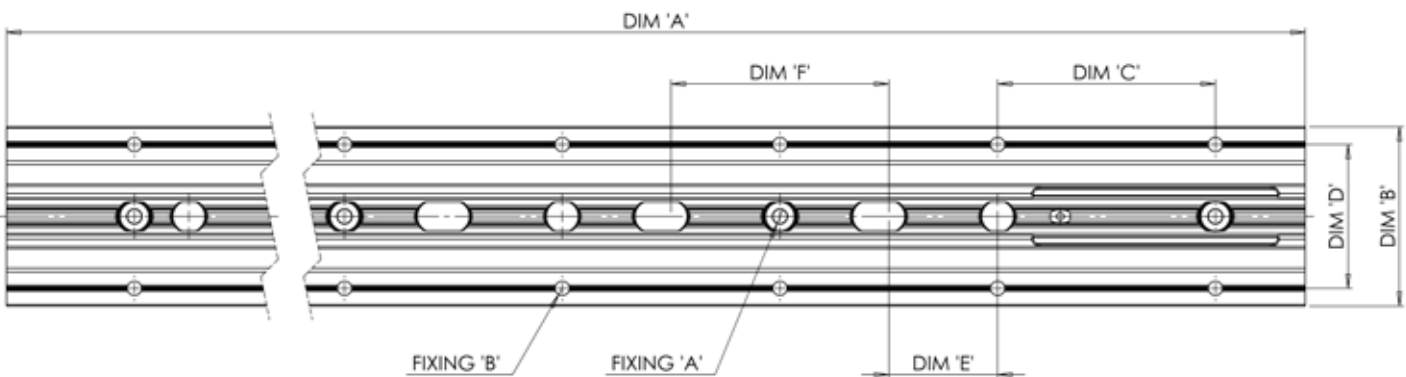
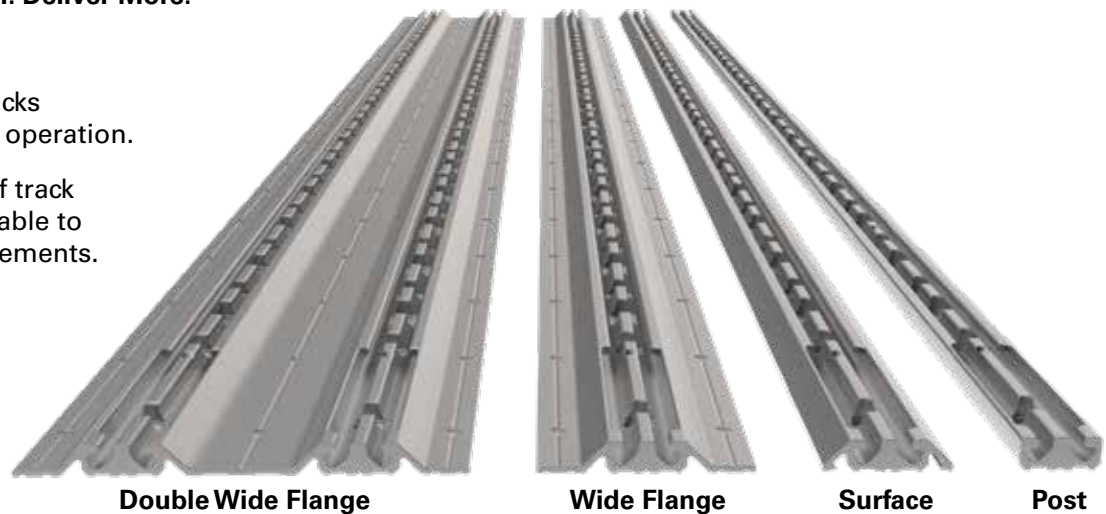

Track Type	Part No.:	Dimensions						Fixings		Weight (lbs.)
		A	B	C	D	E	F	A	B	
Post	33601070	72"	1.22"	4"	-	2"	4"	1/4" 100° Countersink	0.26"	2.56
	33601006	90"	1.22"	4"	-	2"	4"	1/4" 100° Countersink	0.26"	3.30
Single	33601071	72"	1.96"	4"	-	2"	4"	1/4" 100° Countersink	0.26"	3.20
Single WF	33601072	72"	3.29"	4"	2.64"	2"	4"	1/4" 100° Countersink	0.26"	4.02
Double WF	33601074	72"	6.79"	4"	6.14"	2"	4"	1/4" 100° Countersink	0.26"	8.20

The table displays standard sizes for layout and track interface geometries.

Captive Beams

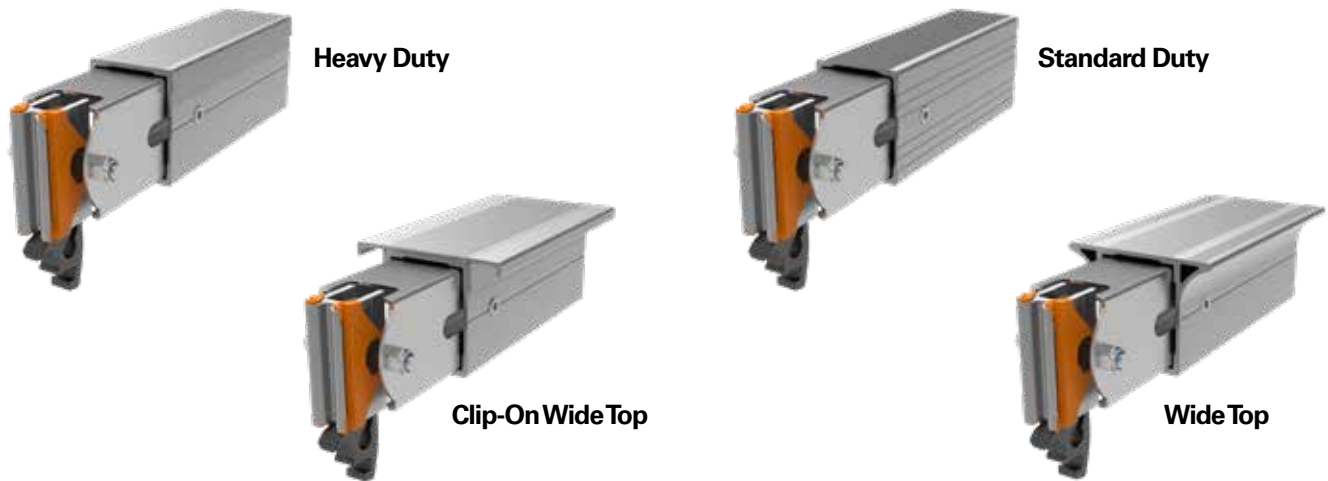

Built for Strength. Engineered for Versatility.

Heavy-Duty Wide Top Beam – Enhanced surface area delivers unmatched stability and support.

Standard-Duty Beam – Reliable, flexible, and ideal for general freight applications.

Heavy-Duty Beam – A stronger, more rigid option for higher load-bearing demands. It also serves as the main structure for the Clip-On Wide Top Beam, allowing seamless upgrades anytime.

Clip-On Wide Top Beam – Same strength as the Heavy-Duty Wide Top, but with a modular, replaceable design. If the top is damaged, simply swap it out at a fraction of the cost—without affecting the beam’s main structure.

Maximize performance. Minimize downtime!

Part No.:	Description	WLL Decking (lbs.)	WLL Decking (lbs.)	Max Cargo* (lbs.)	Weight (lbs.)
33600130	90"-100" Standard Duty Beam	2200	1500	550	17.8
33600131	97"-107" Standard Duty Beam				18.7
33600135	90"-100" Heavy Duty Beam	3000	2500	750	20.2
33600136	97"-107" Heavy Duty Beam				21.2
33601049	90"-100" Wide Top Beam	4000	-	1000	25.5
33601050	97"-107" Wide Top Beam				27.0
33601055	90"-100" Clip-On Wide Top Beam	4000	-	1000	25.5
33601056	97"-107" Clip-On Wide Top Beam				27.0

*Max Cargo is the maximum recommended cargo weight per beam, accounting for expected 4G transport dynamics.

Track Fitting and Release Bars



33607300



33600065



33600064

Fitting can be sold separately or incorporated into any strap required.

Unique, Modular, Replaceable,
Clip-On Wide-Top Beam

Revolutionary Wear-Resistant
Foot Assemblies with Patented
Clip-on Pads

ProDeck™
By Doleco

The ProDeck™ Advantage

- Increased payload efficiency leads to lower transportation costs.
- Enhanced durability means fewer replacements and reduced downtime.
- Customizable solutions tailored to your fleet's unique needs.
- Seamless integration with existing trailer systems.
- Join the logistics revolution and experience the future of double decking with ProDeck™ by Doleco.



www.doleco-usa.com

Doleco USA, Inc.

Office: 290 Pratt St.
Meriden, CT 06450
Phone: 203-440-1940
Fax: 203-440-1950
E-mail: sales@doleco-usa.com

Warehouses:

Main: 9405 D. Ducks Ln.
Suite D
Charlotte, NC 28273
Western: 2535 N. Hayden Island Dr.
Bldg. C
Portland, OR 97217



See our full line catalog online at
www.doleco-usa.com/literature